



**Instruction Book for
FAST-FOLD® SCREEN FRAMES
STANDARD T-LEG**



PROCEDURE

Folding frames are made of 1" square hard aluminum tubing with an anodized finish. With proper care they will provide many years of use. Please follow the set up instructions below (steps 1-5).

1. Remove the frame from its case and wrapping. Position it as shown (front view).

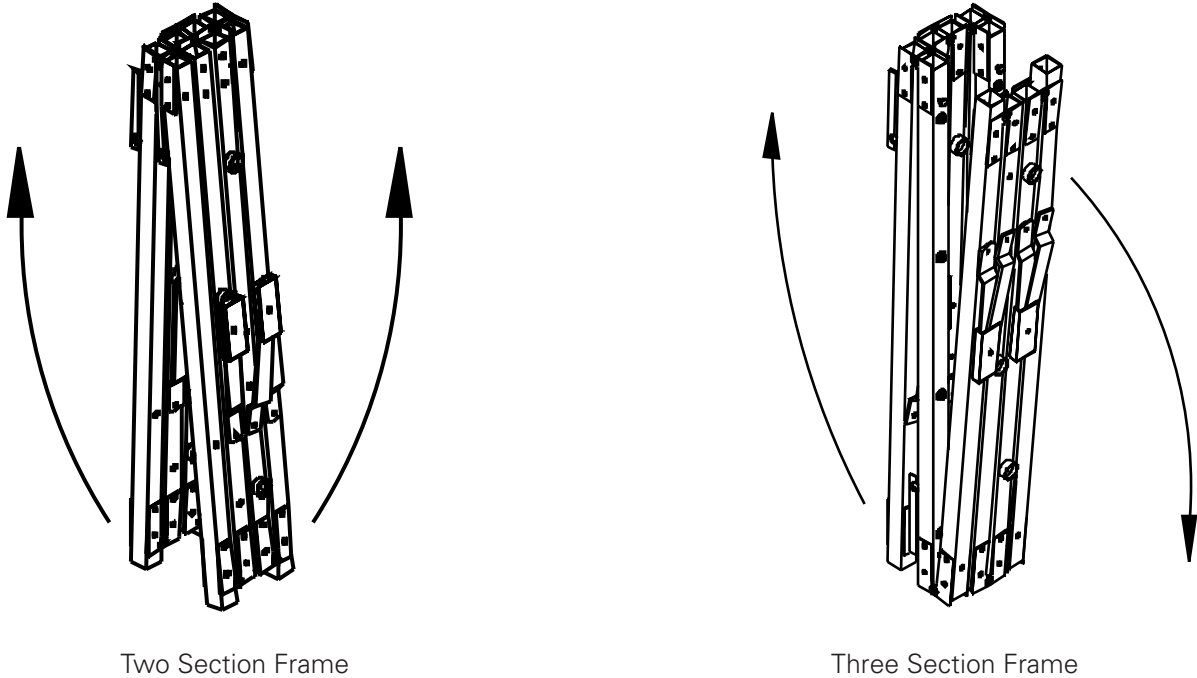

2. Unfold the frame following the directions given below so that it is lying flat and latches are facing up (top view).

LOOKING FROM THE TOP

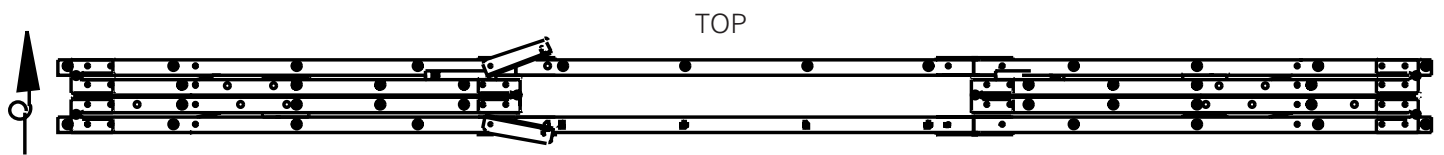

ROTATE 90°

3. Rotate the frame 90 degrees as shown below (front view).

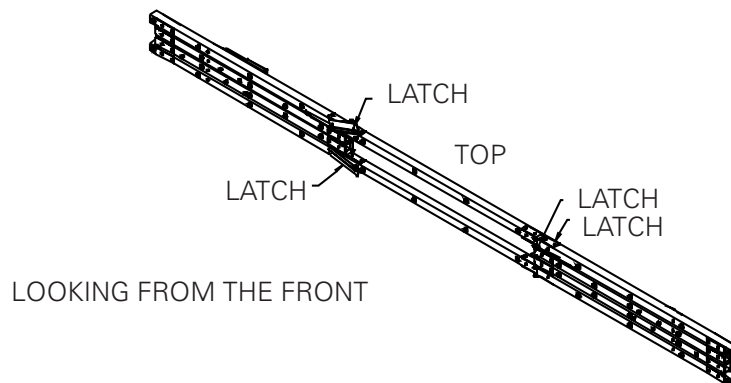

LOOKING FROM THE FRONT

PROCEDURE

4. Rotate the latches on both sides until they lock with the rivets as shown below.

ROTATE LATCH UNTIL IT LOCKS
WITH RIVET ON BOTH SIDES

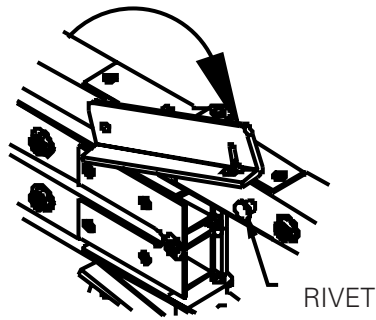

5. While holding the bottom of the frame in place, lift the top of the frame to unfold the sides. Lock down all four corners and all remaining latches.
6. Lay the frame on the floor.
7. Match top of screen surface (labeled TOP) with top of frame.
8. Snap all four corners.
9. Starting at the bottom section, snap the center button. Continue snapping the remaining buttons.
10. Snap the top and sides in the same manner.
11. Attach Leg to each side of frame using at least 2 Speedy Cranks per leg. **NOTE: Speedy Crank at bottom of leg should be on side of leg away from screen.** Do not tighten Speedy Cranks until all are started.
12. Height Adjustment. Fast-Fold® screen height is adjustable in 6" increments either up or down. Normal screen height is 44" from bottom of frame to floor and is the standard height for use with presentation drapery accessories.

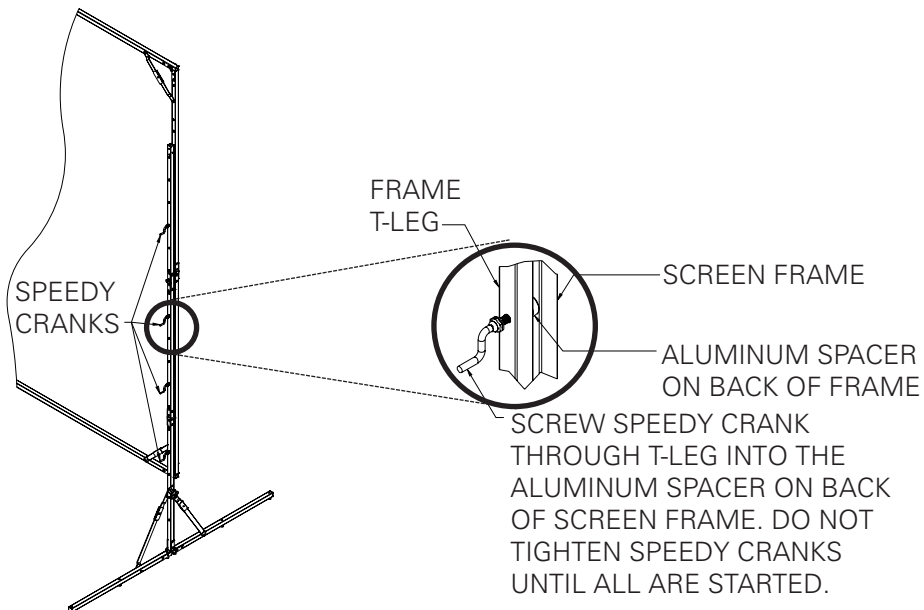
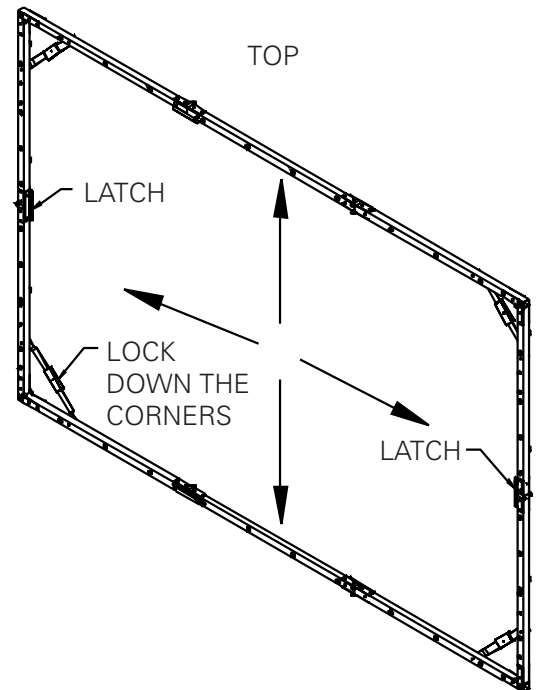

FOLDING THE PICTURE SURFACE FOR PACKING

When folding the screen material for packing, observe the following precautions before proceeding:

1. The surface should not be allowed to contact painted, varnished or plastic finished objects for a prolonged period of time.
2. Make certain the picture surface is on a clean, flat surface.

Then proceed in the following manner:

Place clean white tissue paper – with no printing – on top of the picture surface. If tissue is not available, a soft **white** cloth or something similar will serve the same purpose.

Under no conditions should newspaper or anything similar be used since these may damage the screen material.

1. With the viewing side facing up, fold the fabric in half from top to bottom. Make certain when folding, the surface does not come in contact with either the black binding, grommets or snap buttons.
2. If the material on the first fold is more than 3 feet high, then fold once again, but always place clean tissue paper between the folds.
3. For large size screens, fold in half again if necessary. Make certain when folding, the surface does not come in contact with either the black binding, grommets or snap buttons.

4. After the top to bottom folding procedure is completed, then fold from left to right and continue folding until the fabric is of sufficient size to fit into the leatherette case.

NOTE: Keep the screen surface in the envelope provided when it is not in use. Failure to observe these normal precautions may cause discoloration of the material.

CLEANING

Da-Tex®, **High Contrast Da-Tex®**, **Dual Vision**, **Cinema Vision**, **Pearlescent** and **Da-Mat®** surfaces can be cleaned as follows:

Using a white clean cloth (100% cotton preferred) that is dampened with clear water, gently wipe the area in one direction. Do not use a circular motion. Using a dry 100% cotton cloth, wipe dry after each cleaning session. To clean a stubborn stain or a sticky surface, use denatured alcohol (methanol or methyl alcohol) following the same procedure as for water. For extremely stubborn stains, use V M & P, Naphtha or Super Naphtha and follow the same procedure as for water.

NOTE: Fast-Fold® screens are shipped with tissue paper packed between the folds. This keeps the material from sticking to itself and makes it easier to unfold.

HANDSOME THEATRE-LIKE SET CREATED WITH FAST-FOLD® PRESENTATION DRAPERY ACCESSORIES

For a finished, professional appearance, Fast-Fold® screens can be dramatically enhanced with the Drapery Presentation Accessory Kit. Handsome velour drapes in a choice of two eye-catching colors surround the screen on four sides, providing an attractive stage front to the audience.

The Presentation Drapery Accessory Kit serves a second function when used with a rear projection surface. It shields extraneous light from the projector as well as hiding projection and other equipment from the audience.

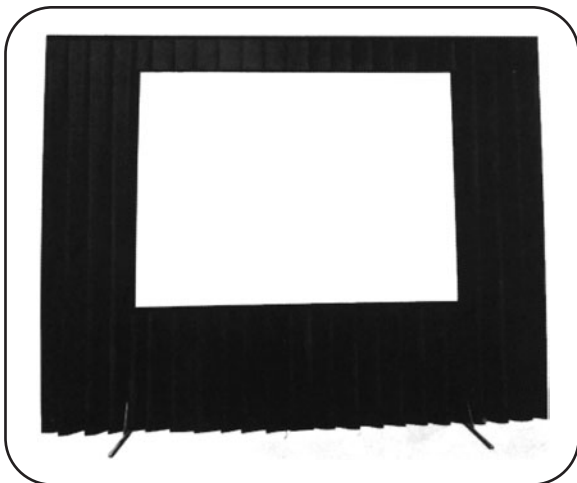

An optional Adjustable Skirt Bar provides a versatile method of changing the picture ratio.

The hardware in the kit is made of lightweight aluminum and, along with the folded velour drapes, is packed into a convenient easy to carry poly case. The entire kit can be set up in minutes. Case optional at additional cost.

Presentation Drapery Accessory Kit (ILLUSTRATED)

Consists of a set of velour drapes in choice of Blue or Black, Valance, two Wings, Skirt, Valance Bar, and two Wing Bars.

- All bars attach to screen frame with slip on clamps. No tools needed.
- Valance Bar attaches to frame first. Wing Bars then attach to Valance Bar.
- Valance Bar extends 12" above frame. Wing Bars extend 32" on each side.
- Wing Bars attach to frame when ceiling height prevents use of Valance.
- 45" High Skirt snaps to bottom of screen or to optional Adjustable Skirt Bar.